



INDIRA GANDHI INSTITUTE OF TECHNOLOGY
SARANG, DHENKANAL, ODISHA –759146

No.IGIT/FC/02 Date 28.07.2016

TENDER CALL NOTICE

Sealed Tender are invited for below items from different firms / suppliers having experience in supply of Hostel furniture including SS items with registration under VAT/Valid PAN/TIN Numbers or DGS&D rate contract for supply of different furniture to I.G.I.T., Sarang, Dhenkanal. The interested firms/suppliers may collect details list of drawings, specifications and other related documents which are available in our website. Other wise before submitting tender the interested firm/supplier may visit as noted below to the Institute and to look out the design and specification of furniture in hostels / Cafeteria 02 (For Dining Table).

The details quotations completed in all respect may be submitted in sealed envelope in the office of the **Director, (Special attention to Chairman, Furniture Committee) I.G.I.T. Sarang , Dist; Dhenkanal-759146 (Odisha) by speed post /Registered post** under strong sealed cover marked as **“TENDER FOR THE SUPPLY OF FURNITURE”**..

The last date of submission of quotation is **08.08.2016 up to 3.00 P.M.** The same will be opened on the same day at **3.30 P.M** at Conference Hall, IGIT Sarang in presence of the suppliers or their authorized representatives.

The authority reserves the right to reject one or all Tender partially or wholly without assigning any reason thereof.

Visit us at **www.igitsarang.ac.in** for details.

Sl. No.	Particulars	Important dates	Time
1	Pre-bid meeting at Conference Hall, IGIT Sarang	01.08.2016	11.30AM to 12.30 PM
2	Last date & time for submission of tender	08.08.2016	03.00 PM
3	Date and time of opening of Tender	08.08.2016	03.30 PM

Sl. No.	Items	Estimated cost	EMD	Tender fee (Non refundable)
1	Steel Cot	2709700.00	27097.00	500.00
2	Steel Table	621200.00	6212.00	500.00
3	Moulded chair with arm (SKY BLUE Colour)	280000.00	2800.00	500.00
4	S.S Dining Table	450000.00	4500.00	500.00

REGISTRAR

INDIRA GANDHI INSTITUTE OF TECHNOLOGY
SARANG, DHENKANAL (ODISHA) - 759 146
Terms and Conditions for submission of Tender for supply of furniture

Ref:- **Tender Call Notice No.IGIT/FC/ -02 Dated. 28.07.2016 which published on local daily leading News paper. (English / Odiya)**

1. Sealed tender for the supply of the shown in the tender Call Notice are invited by the undersigned up to **3.00 P.M. Date.08.08.2016.**
2. The tender should be sent to the **Director, (Special attention to Chairman, Furniture Committee) I.G.I.T.Sarang ,Dist; Dhenkanal-759146 (Odisha) by speed post /Registered post** under strong sealed cover marked as **“TENDER FOR THE SUPPLY OF FURNITURE’** and not by the name. The Tender will be opened in the office of the **Director, I.G.I.T., Sarang** on same day at **3.30 P.M.**
3. The tender should be submitted according to the terms and conditions specified in paragraphs 4 to 15 unless specified in otherwise in the tender, it shall be treated that the terms and conditions stipulated have been agreed.
4. The rate should be **F.O.R., IGIT, SARANG** and should include Excise Duty, Sales Tax, VAT and any other taxes, or imposition whatever (each specified) liable in respect of the supplies.
5. Each page of the tender is certified with signature and seal of the firm. No claim will be entertained if there is no signature on each page.
6. There should not be any over writing, corrections in the tender If a figure is to be amended, it should be neatly scored out and then revised figure should be written above and the same should be attested with full signature and date. In the absence of the attested signature the tender is liable to be rejected.

Contd....P/2.

PAGE-2

7. The authority does not bind part i.e. with respect to all the articles mentioned in the tender call notice or in respect of any one or more than one articles specified in the tender call notice as may decided. On the acceptance of the lowest rate as per the decision of the Furniture committee, P.O. will be placed to the supplier and the supplier shall be bound by the terms and conditions of the P.O. as per the provision of **O.G.F.R./ IGIT, Sarang.**
8. **Period of delivery is within one month from the place of order.**
9. If the supplier fails to supply the articles within the time stipulated in the letter of acceptance by the undersigned, the undersigned shall be at liberty to purchase the articles from the market or get the rest of the contract completed by any other person of firm.
10. The quantity of articles indicated in the attached statement may be increased or decreased at the discretion of the authority without assigning any reason.
11. Prior to acceptance of the Quotation, the undersigned reserved the rights to call for samples or demonstration and the Suppliers shall be liable to supply the sample given the demonstration free of cost.
12. The rate quoted by the supplier shall hold good up to **31st Dec.2016** No amount amendment in the rate except increase/ decrease in the rate of sales tax during the period of supplies will be accepted.
13. In the event of acceptance of the quotation and placing of the order for purchase, the articles ordered for would be subjected to an inspection by the undersigned or his representative and are liable to be rejected if the articles supplied are not according to approved samples or do not confirm to the specifications prescribed.
14. Quotation which does not comply with the above conditions is liable to be rejected.

Contd.....P/3

PAGE-3

15. The sealed tender is liable to be rejected if does not contain (should invariably contain):-
- i) Current Commercial Tax, VAT,ITCC and other Tax clearance certificate from the competent authority.
 - ii) Copy of the TIN No. of concern firm.
 - iii) Copy of permanent registration certificate from the commercial department.
 - iv) Lowest rate as well as terms of supply and payment terms and conditions if any.
 - v) Specification and printed catalogue and other concerned literature.
 - vi) In case of authorized Dealers, Authorization letters from the manufacture/supplied.
 - vii) Signature of the authorized person on all pages of the quotation with date and seal.
 - viii) The Bid documents can be downloaded from the official website of IGIT Sarang (www.igitsarang.ac.in). The bidders have to down load the bidding documents from the internet site and to pay the cost of bid documents in the form of Demand Draft issued from any schedule Bank payable at SBI IGIT Saranga (10246)in favour of Principal, IGIT Saranga (IFSC CODE : SBINOO10246)

**Chairman,
Furniture Committee**



INDIRA GANDHI INSTITUTE OF TECHNOLOGY
SARANG,DHENKANAL,ODISHA –759146

No.IGIT/FC/02 Date 28.07.2016

TENDER CALL NOTICE

Sealed Tender are invited for below items from different firms / suppliers having experience in supply of Hostel furniture including SS items with registration under VAT/Valid PAN/TIN Numbers or DGS&D rate contract for supply of different furniture to I.G.I.T.,Sarang, Dhenkanal. The interested firms/suppliers may collect details list of drawings, specifications and other related documents which are available in our website. Other wise before submitting tender the interested firm/supplier may visit as noted below to the Institute and to look out the design and specification of furniture in hostels / Cafeteria 02 (For Dining Table).

The details quotations completed in all respect may be submitted in sealed envelope in the office of the **Director, (Special attention to Chairman, Furniture Committee) I.G.I.T. Sarang , Dist; Dhenkanal-759146 (Odisha) by speed post /Registered post** under strong sealed cover marked as **“TENDER FOR THE SUPPLY OF FURNITURE”**..

The last date of submission of quotation is **08.08.2016 up to 3.00 P.M.** The same will be opened on the same day at **3.30 P.M** at Conference Hall, IGIT Sarang in presence of the suppliers or their authorized representatives.

The authority reserves the right to reject one or all Tender partially or wholly without assigning any reason thereof.

Visit us at www.igitsarang.ac.in for details.

Sl. No.	Particulars	Important dates	Time
1	Pre-bid meeting at Conference Hall, IGIT Sarang	01.08.2016	11.30AM to 12.30 PM
2	Last date & time for submission of tender	08.08.2016	03.00 PM
3	Date and time of opening of Tender	08.08.2016	03.30 PM

Sl. No.	Items	Estimated cost	EMD	Tender fee (Non refundable)
1	Steel Cot	2709700.00	27097.00	500.00
2	Steel Table	621200.00	6212.00	500.00
3	Moulded chair with arm (SKY BLUE Colour)	280000.00	2800.00	500.00
4	S.S Dining Table	450000.00	4500.00	500.00

REGISTRAR

INDIRA GANDHI INSTITUTE OF TECHNOLOGY:SARANG

NO.IGIT/FC/ 03 Dated. 28.07.2016

Website Manager,

As per approval the advertisement of quotation Call notice for procurement of Hostel Furniture is enclosed herewith for publication in News paper and our institute website. You are requested to take immediate action as the matter is urgent

Chairman,
Furniture Committee

CC:

1. Registrar for necessary information.
2. PA to Director for kind information of the Director.

INDIRA GANDHI INSTITUTE OF TECHNOLOGY SARANG

FURNITURE ITEM NO. 1

Ref. To our Tender call notice FC / 02/28.07.2016

Sl. No.	Name of Items	Specification	Unity	Rate quote by the firm
1.	Steel Cot SIZE : 6'- 6" L x 3'- 0" W x 1'- 6" Height	Legs: 45-50 mm dia x 2 mm thickness MS pipe & foot also covered with same size washer . Top portion of frame made of 25x25x5 mm MS Angle support with MS Angle 25x25x5mm, 30x30x5mm & MS flat of 35x5 mm covered with (flush type) 18 mm thickness water proof ply board ISI marked (with number) which screwed with frame as per design drawing {enclosed} with Mosquito net stand ¾" M.S pipe of 2mm thickness Painting of frame: One coat of red oxide primer & two coats of Hammer tone paint of Grey color. Minimum Weight of the bed frame without ply board is 25 kg and the minimum weigh MN stand is 7 kg.		

Signature and seal of the firm

DRAWING OF M.S COT WITH MOSQUITO NET

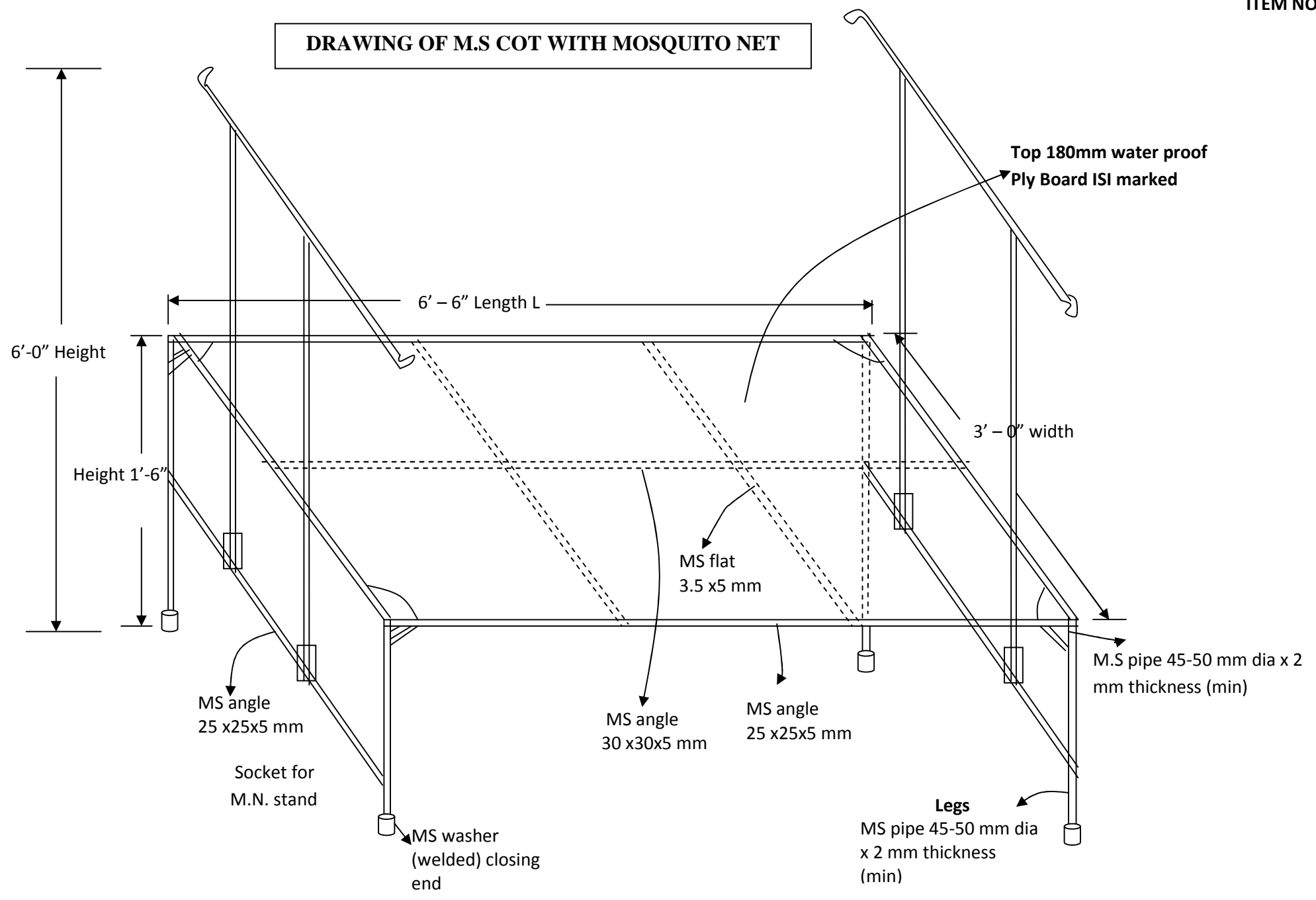

INDIRA GANDHI INSTITUTE OF TECHNOLOGY SARANG

FURNITURE ITEM NO. 2

Ref. To our Tender call notice FC / 02/28.07.2016

Sl. No.	Name of Items	Specification	Unity	Rate quote by the firm
2.	Steel Table (Study Table for students) SIZE: OVER ALL 3'-0"L x 2'-0"w x 2'-6"Height	Legs: Made of 25 x 25 x5mm Angle with support Top frame :Made of 25x25x5mm M.SAngle & covered with (flush type) pre laminated Medium Density Fiber Board 19mm thick with counter shank bolt & nut (8 nos) as per design drawing (enclosed) Painting of frame: One coat of red oxide primer & two coats of Hammer tone paint of Grey colour. Minimum Weight of the table frame without MDF board is 14 kg		

Signature and seal of the firm

DRAWING OF ITEM NO. 02 Steel Table

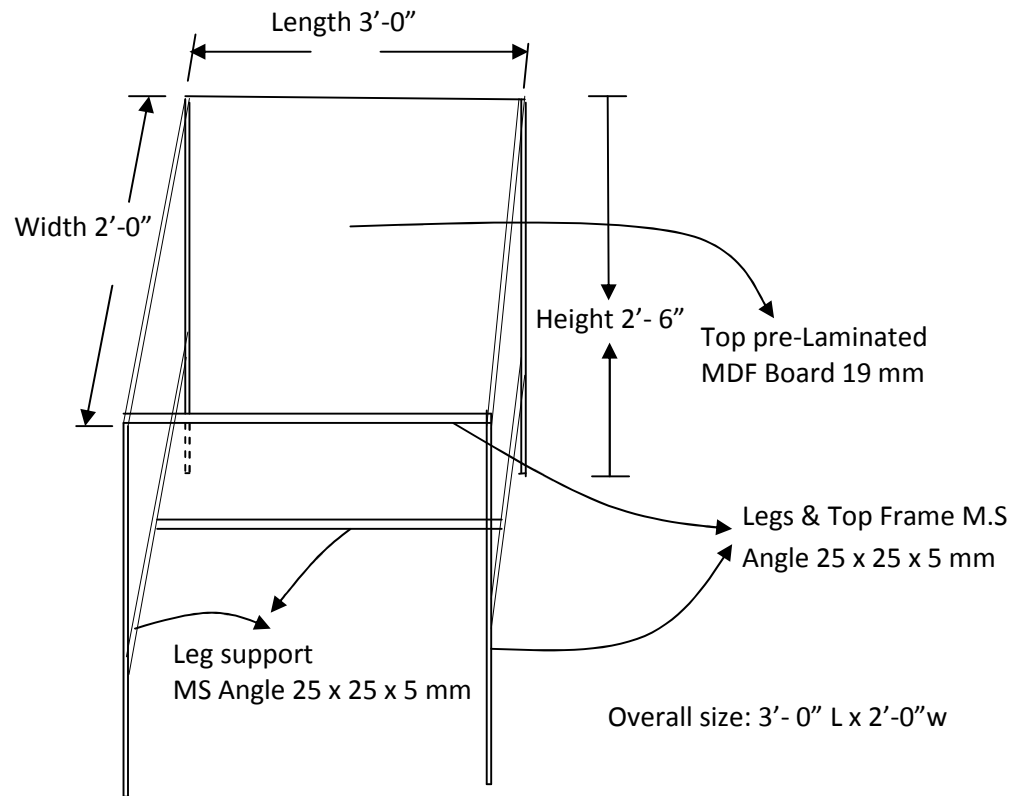

INDIRA GANDHI INSTITUTE OF TECHNOLOGY SARANG

FURNITURE ITEM NO. 3

Ref. To our Tender call notice FC / 02/28.07.2016

Sl. No.	Name of Items	Specification	Unity	Rate quote by the firm
3.	Moulded chair with arm (SKY BLUE Colour)	Model CH-18 (Moderna Make) of blow Plast ltd.		

Signature and seal of the firm

INDIRA GANDHI INSTITUTE OF TECHNOLOGY SARANG

FURNITURE ITEM NO. 4

Ref. To our Tender call notice FC / 02/28.07.2016

Sl. No.	Name of Items	Specification	Unity	Rate quoted by the firm
4.	S.S.Dining Table Size:8'-0"L x 4'-0"W x 2'-6"Ht.	Table frame: M.S. Square tubular structure of 40mm with anti rust double enamel paint Top: For dining with Stainless Steel top (8'x4'approximately) (SS 304) and seat top: Stainless Steel round of standard size 8 seater (4 + 4) both side. Special attention: The exact specification & measurement and materials are as per our dining table AVAIBLE AT CAFETERIA-02, IGIT SARANG. Kindly refer the specification. Minimum Weight of the table with 8 seater is 90 kg		

Signature and seal of the firm

